

How to Design an Air Cooled Cigar Humidor (Thermal Conductivity of Wood and Glass)

By Jim Forgione

Release: Final, Rev 4: 8/8/08

Email: jforgione@prodigy.net

Abstract:

In order to use a Thermal Electric (TE) cooling device as the cooling element in a cigar humidor, you must generate a realistic estimate of the Thermal Conductivity (T/C) for the cigar humidor. To do this, you must know the T/C for the wood, glass and other elements that it's made from. Typically a wood humidor is made from sandwiched layers of plywood, cedar and veneer. The top (or door) may be glass and this further complicates finding a realistic T/C. To accurately size the heat load (BTU/hr) for the TE device, going through the steps outlined in this paper will ensure that you will have an adequately cooled cigar humidor even under high ambient temperature conditions.

The first section contains the material analysis; the latter sections contain the actual TE sizing calculations, thermal modeling examples including thermal modeling sw links. Later, the TE is chosen, installed and tested. Problems found are fixed. Finally, the Appendix contains T/C of various everyday materials including those used in a humidor.

The last section details the cause of the excessive humidity levels that plagued this investigation. Details start on pg 26. The "break-through" starts on PG 29. Please read those sections.

Plywood:

Thermal insulation and warmth-keeping properties of thick plywood-faced sandwich panels with low-density fiberboard (plywood-faced sandwich, PSW), which were developed as wood-based structural insulation materials for walls and floors, are clarified here. The properties focused on were **thermal conductivity (T/C)**. **The T/C values for panels with densities of 340 kg/m³ (PSW350) and 410kg/m³ (PSW400) were 0.070 and 0.077 W/mK, respectively.**

Consequently, the PSW provided thermal insulation properties superior to those of the boards and in terms of warmth-keeping properties were greatly advantageous over the insulators. These advantages were due to the moderate densities of PSW panels. The PSW panel with sufficient thickness showed remarkably improved thermal resistance compared with those of the boards.

Cedar:

Cedar is the perfect timber candidate under almost any climatic conditions because of its: low wood density, low shrinkage factor and finally, low absorption of water

Red cedar has excellent dimensional stability because of its low wood density and lowest shrinkage factor of all major softwoods. A major contributor to this stability is the fact that its moisture content at the fiber saturation point is 18 to 23%, compared to 25 to 30% in most softwoods. As a result, red cedar shrinks and swells minimally, is not subject to warping or twisting, and displays only small movements with changes in humidity.

Lower absorption of water is a result of the high extractive content blocking absorption sites. This property contributes to red cedar's suitability for use in paneling, moldings and a number of other applications such as saunas and cigar humidors where dimensional stability and water repellency is important.

Thermal and Insulating Properties

Red cedar has good insulation value because of its low wood density and coarse texture. It is the best insulator among the most common available softwood species and is far superior to brick, concrete and steel. This property ensures that homes built with red cedar will be cooler in the heat of summer and warmer in winter as opposed to homes using denser species or man-made products. Red cedar's ability to dampen vibrations is an important acoustical property that makes it particularly effective as paneling and molding where it is desirable to reduce or confine noise. **The T/C (K) of red cedar is 0.0932 W/m-k.** Please refer to the Appendix for more information on 'softwoods'.

Determining Humidor Thermal Conductivity:

The problem to 'accurately' determine the composite T/C is somewhat of a challenge b/c it's definitely not homogeneous!

My humidor is constructed of cedar over plywood with the final layer being a cherry wood veneer. The outside dimensions are 24.5"Wx25.5"Dx30" H. Internal dimensions are **22"W x 23"D x 28"H**, making it just under 8 cu ft (7.8cu ft).

The picture shows my humidor. It was built in Tennessee about 16 years ago. The outside is cherry wood veneer while the inside is double-lined with red cedar over $\frac{3}{4}$ " thick plywood. The inset picture shows the door gasket with my added double seal. The seal holds 70% humidity even on days of a Santa Ana condition where the RH drops to 10%.



We have seen that red cedar has T/C of **0.0932**. Plywood (low density) has a T/C of **0.070**.

It gets more complicated b/c the humidor has a 'glass' top with the stated T/C of **0.96**. This is extremely poor thermal insulator that will cause most of the TE's air-cooling power to be wasted! So the glass must be replaced or augmented with a better T/C material. One such readily available material is acrylic Plexiglass with a T/C is **0.19**. This will result in an **080% decrease in the thermal loss through the glass**. A worthwhile thing!

That's not the end of the good news! As the picture shows, the glass-top will be augmented with Plexiglass by adding a $\frac{1}{4}$ " sheet mounted under the existing glass top maintaining a $\frac{1}{4}$ " air gap using a precision piece of clear Plexiglass. This will make a "sealed" sandwich of **Plexiglass-Air-Glass**. The overall TC of this composite top is approximately that of air, which is **0.024**. Being conservative, I'll use **0.061** based on the calculations involving the total volume vs the Plexiglass-air-glass interface.

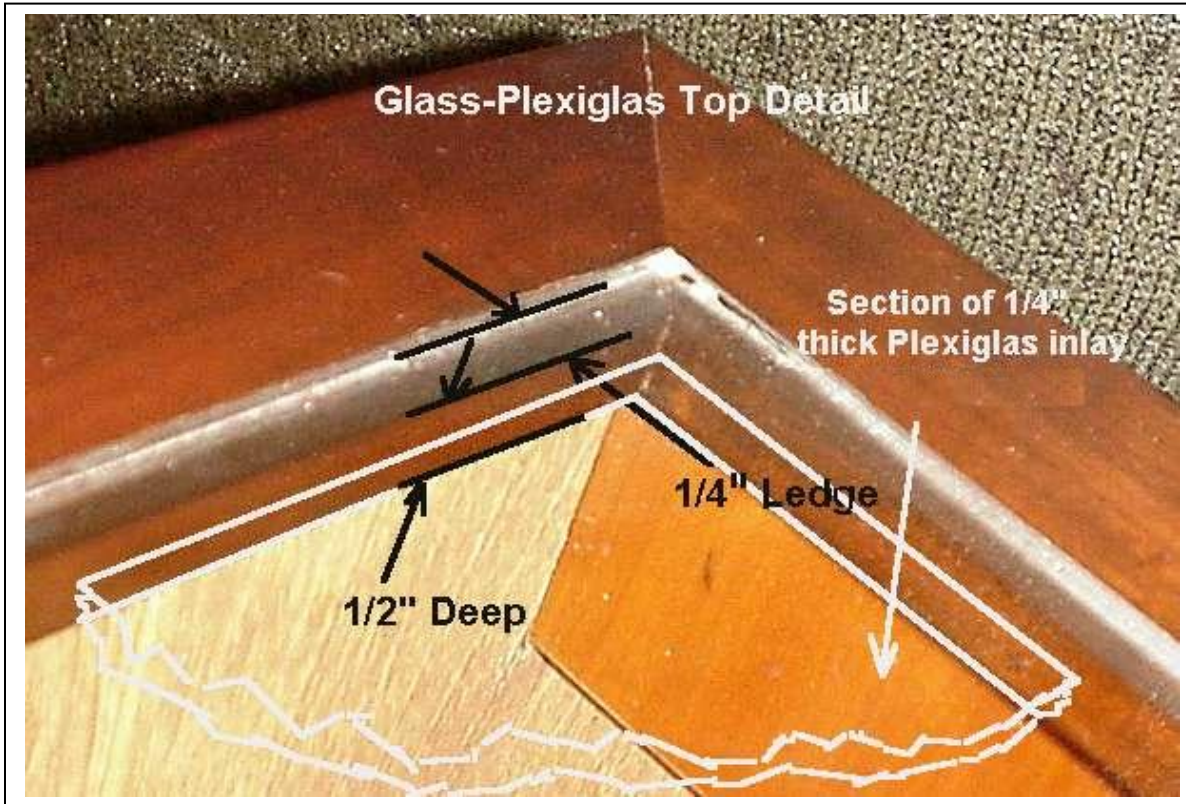

One of the bad features of Plexiglass is the expansion due to temperature and humidity.



Temperature won't be a problem but the humidity will cause it to expand about 0.050" for a 20" square piece.

This needs to be considered when it's cut. For 70% RH, apx $3/64$ " (0.046") will be subtracted from the desired dimensions.

The Plexiglass was mounted as shown in the picture above. Everything went as planned with no difficulties other than the Plexiglass edges were sanded to fit the non-rectangular cabinet. To maintain the $1/4$ " air layer, $1/4$ " spacers were used as shown above. To secure the Plexiglass, hot-glove from a 'glue-gun' was used. The seal is excellent and it remains flexible in order to take the expansion and contraction of the Plexiglass.

Door Insulation:

The next area of concern is the door. It's not lined and is 1" thick on the frame edges but $3/16$ " in the middle cutout portion. The door was insulated using a $1/2$ " thick piece of Styrofoam cut to 19"x20". When the door is closed, the Styrofoam panel adds to the cabinet seal already in place.

Styrofoam's T/C is **0.033** and is a closed-cell material so it does not hold water. A good use for it here.

The T/C of the wooden door is apx 0.12 - 0.17. Combine this with the Styrofoam (0.033) and you can conservatively say the composite is close to 0.033 but I backed off to **0.077**.



Arriving at a "Composite" T/C:

The sketch shows the conceptual breakdown of the humidor based on six (6) faces. As you see, four (4) of the six sides are equal. The door and the top are different. Adding all the sides, bottom and top T/C numbers give the composite conductivity of **0.077** for estimating the thermal heat-load Q_c using the "Aztec" simulation sw.

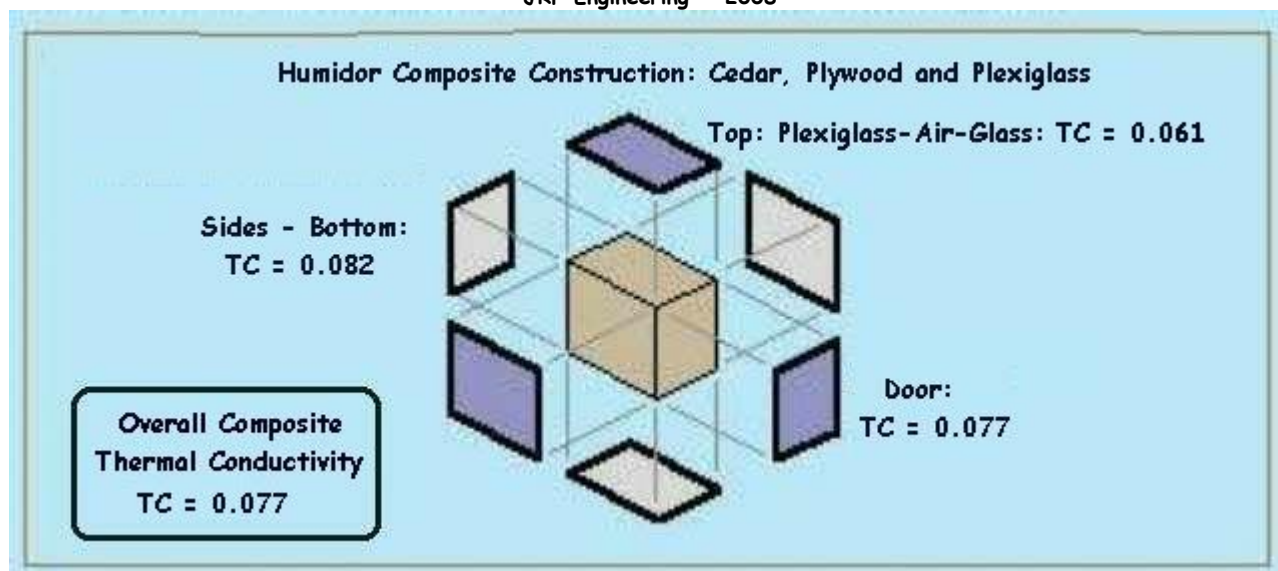

The number arrived at here is very conservative and should give meaningful results.

TE Coolers:

All TE modules to date have been evaluated (on paper) to meet or exceed these two cooling-power levels. Any TE air cooler capable of greater than 45 watts of cooling are considered as a possible candidate. Here's what I looked at so far;

<u>Supplier</u>	<u>Model #</u>	<u>Cooling (W)</u>	<u>Price(\$)</u>	<u>Comments</u>
TE Tech	AC-046	46*	294	Needs PS + Controller
TE Tech	AC-073	73	444	Needs PS + Controller
TECA	AHP-300FF	57	475	Needs PS + Controller
TECA	FHP-450XE	40*	645	Needs PS + Controller
EIC	AAC-120	60	750	Complete w/ built-in tstat + PS
EIC	AAC-140	90	650	Requires DC power + drip catch
EIC	AAC-400	90	1130	Complete w/ built-in tstat + PS
Melcor	MAA150T	44*	TBD	Needs PS + Controller
Melcor	MAA260T	82	TBD	Need PS + Controller

ISC Products have the same P/N as "EIC" . . so they are made for them!

** Items marked may be 'marginal' and may not meet worst-case conditions.*

LINKS:

- TE Tech Home Page: <http://www.tetech.com/> --- Use the online TE Analysis SW
- TECA Home Page: <http://www.thermoelectric.com/> --- Download their TE Analysis Sw
- EIC Home Page: <http://www.eicsolutionsinc.com/>
- ISC Home Page: <http://www.iscenclosurecooling.com>
- Melcor Home Page: http://www.melcor.com/index_melcor.html --- Download their TE Analysis SW for Windows; used this for thermal load analysis summarized on page 4; actual analysis is pg 8.

Choosing the TE Air Cooler for my Cigar Humidor

After comparing the various TE air coolers from four (4) manufacturers, the products from EIC appear superior to others. The main reason is the 'total' solution involving all fundamental considerations such as the 'condensate' drainage. Other manufacturers do not address this and thus become not usable for a cigar humidor application.

The two MAIN problems for a cigar humidor are; maintaining proper humidity (around 70%) and maintaining proper temperature (normally 70 F).

Two candidates that I have evaluated are the AAC-120-4XT and AAC-140-T. The former is a 200 BTU/hr unit while the latter is a 400 BTU/hr cooler.

AAC-120-4XT:

The picture shows a self-contained TE cooler ready to mount into the humidor. The view shown is the "cold-side", the side that mounts inside of the humidor.



Inspection shows that it has an external power supply (PS). It's nothing fancy; it contains a transformer, rectifier and large value filter cap. The output plugs into a convenient jack on the TE A/C. To the right, there's a continuous variable control (potentiometer) for setting the neutral point. For my application 70F will be the desired set point. According to EIC, it's calibrated on the front decal, so you can set it to be within +/- 3 degs F of the desired point.

*One of the biggest problems that you will face is the "condensation" that collects on the cold side. Since a cigar humidor is kept at 70% RH, the TEC will run 3 to 4 degrees cooler meaning that condensation will build b/c that temperature is below the dew point. Thus it **will** produce condensation on a continuing basis. This must be "processed" in some manner otherwise the humidity in the humidor will rise to a dangerous value.*

As you can see, EIC has thought of the problem and have built-in a condensation 'catcher'. The outside case is formed and dimpled to a drain hole that accepts a brass fitting and a small vinyl hose that drains the condensate outside of the humidor.

Mounting:

This unit mounts as shown in the picture below. This shows that it mounts at the halfway point at the junction of the hot and cold side. There's a gasket that ensures the humidor is sealed. The cold side contains all of the required interfaces meaning that the unit's power cord will exit via the bottom access hole in the humidor.



This is experimental but I plan to determine whether I can "use" the condensate to provide the required humidity to the humidor **and**, at the same time, cool it. If so, that will eliminate the humidifier that's currently being used. This looks promising. [Please read the "Temperature-Humidity Management" section starting on pg 22 and the final section starting on pg 29.]

Specifications:

AAC-120-4XT Thermoelectric Air Conditioner - 200 BTU Cooling Through-mount - NEMA 4X



Thermoelectric Air Conditioner - 200 BTU Cooling Through-mount - NEMA 4X

Compact, lightweight, thermoelectric cooling system for electronic and computer enclosures in harsh industrial settings. Unit features a simple, efficient solid-state design for reliable performance.

Specifications	Air Conditioner Options
<u>Capacity</u>	200 BTU/HR cooling Through Mount
<u>Rating</u>	NEMA 4X - outdoor/wash down
<u>Construction</u>	Stainless steel (covers and mounting flange)
<u>Size</u>	7 1/4"H x 5 1/8"W x 7"D body, 8 1/4"H x 6"W flange
<u>Operating Range</u>	Up to 140 degrees F
<u>Temperature Control</u>	Adjustable thermostat
<u>Power</u>	120/220 VAC at 2 AMPS or 24/28 VDC
<u>Frequency</u>	50/60 Hz
<u>Features</u>	Power Supply with Polycarbonate Case & 9' Power Cord
<u>Includes</u>	Self-contained condensate drip pan, mounting hardware and gasket
<u>Weight</u>	10 lbs
<u>Warranty</u>	One year

Link to EIC Air Cooler Page, 200BTU series:

http://www.eicsolutionsinc.com/200btu_thermoelectric_air_conditioner.htm

Calculating TE Thermal Load:

There are a number of TE programs to assist you and one that is extremely adept is **Melcor's Aztec**. Its main advantage is the ability to enter a different T/C computed for your application. That capability is extremely important here since the 'device' is a humidor composed of different materials.

In this example, the 22" x 23" x 28" (7.8 cu ft) humidor requires **41.9 watts** of 'cooling-power' under the conditions of **85 F** ambient temperature (T_a) to ensure that the inside air is at **70 F**. As we saw, the 70F temperature is optimum to ensure proper long-term aging of cigars as well as 70% humidity. There's some argument about this but suffice to say, it's a good starting point.

This condition can also be considered a **WORST-CASE**. However, the probability is very low for this to occur b/c my house is A/C cooled (when needed) during days such as this. But if the house were vacant due to a vacation, this could occur. Under that condition, Q_c is equal to **42 Watts**. This is the size that I used to evaluate all TE candidates. Of course, cost tradeoffs sometime cause you to make some short cuts!

Realistically, an **80 F** temperature rise is a very real-world condition. Under this, the cooling-power required is now reduced to **28 W** instead of 42 W as the Q_c analysis shows. Both TE coolers under investigation can handle this situation.

The Q_c analysis clearly shows that the successful TE air cooler **must** be able to handle at least **40 watts** of thermal load at a temperature difference of 15 degs F. The insulation properties T/C was 0.077 based on the composite materials found in the humidor.

The sketch shows what I've defined as worst-case conditions. The ambient temperature (T_a) is 85F. The internal temperature needs to be 70F with 40 watt thermal load to be handled by the TE cooler.

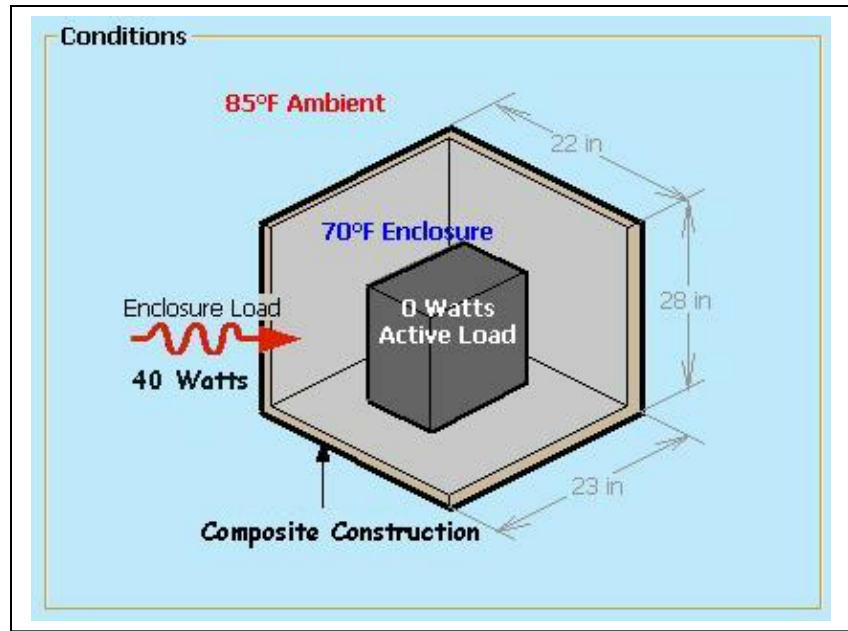

The AAC-120 unit runs out of cooling power at the numbers shown below. It can do apx 38 watts at a 15 deg temperature difference. Is this enough power? It's probably adequate since this is a worst-case scenario. If more cooling power is desired, you need to go to a 400 BTU/hr cooler.

Looking at the chart to the right clearly shows that 40 Watts is the maximum cooling that can be expected from the AAC-120-4XT air cooler for a 15 temperature difference. This corresponds to about 140 BTU/hr cooling power.

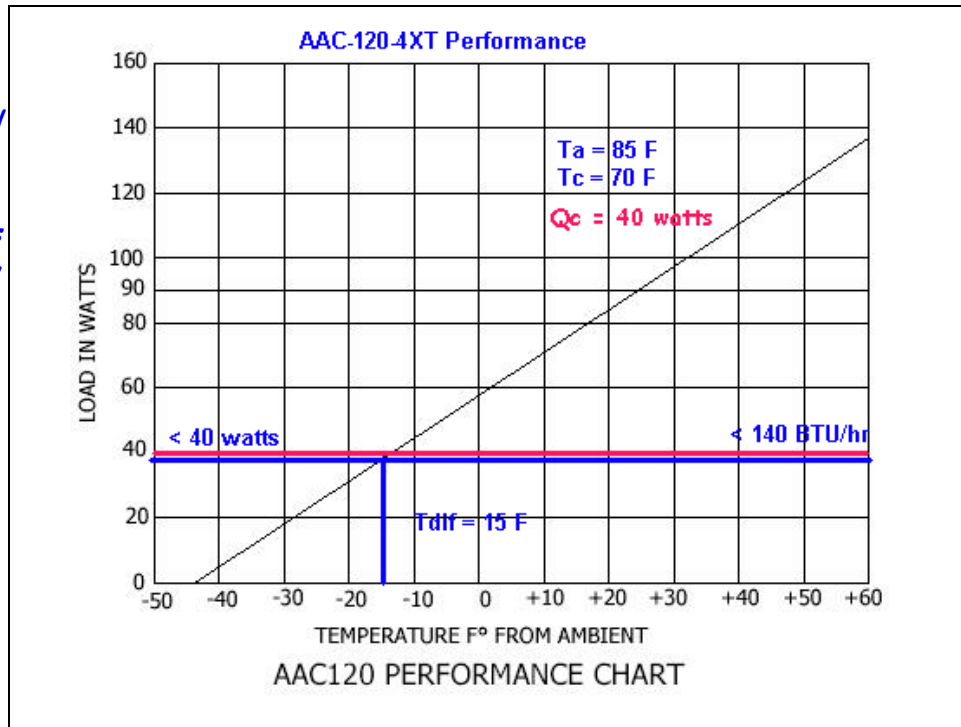

A less expensive way to obtain added cooling power is to add foam insulation to the interior of the cabinet. For my humidor, the glass top was the best place to optimize b/c glass's T/C is 0.96. The technique chosen is discussed on page 3 and 4. This lowered the thermal load so that I can use a lower power TE air cooler. Of course, the temperature range can also be lowered.

The next section shows an alternate TE cooler that will handle larger wattage loads.

AAC-140-T:

This is the alternate design that, as you will see, *guarantees* to be able to cool the cigar humidor under the conditions stated for the previous TE cooler. Ta = 85 F and Tc = 70 F.

The TE cooler is an EIC **AAC-140-T** model featuring **90 watts** of cooling power. This represents a 50% increase in cooling power for *less* cost than the **AAC-120-4XT**, about \$650. However, this unit is "DC" powered so it does need an external 24 Vdc @ 5amps PS. So the total cost is a 'wash' but you do gain an **added 30 watts** of cooling power.

The picture shows that it's similar to the AAC-140-4XT except there's no AC power supply built-in. Also the temperature controller can be remotely mounted. Other than that, the power curve is that of a 400 BTU/hr unit.



The temperature controller, shown below, can be remotely mounted. It must be mounted **inside** the humidor but can be placed in a user convenient spot for easy access. Temperature adjustments can be easily made. A big user plus!



Specifications Air Conditioner Options

Capacity	400 BTU/HR cooling
Rating	NEMA 12 - dust and dirt resistant
Construction	Stainless steel (covers and mounting flange)
Size	6"H x 5"W x 9-7/8"D body, 7-1/4"H x 7"W flange
Operating Range	Up to 140 degrees F
Temperature Control	Adjustable remote thermostat
Power	24-28 VDC, 4-5 AMPS
Frequency	N/A
Includes	Mounting hardware and gasket
Weight	13 lbs
Warranty	One year

Link to EIC Air Cooler Page, 400 BTU series:

http://www.eicsolutionsinc.com/400btu_thermoelectric_air_conditioner_a.htm

This unit requires a "condensate" capturing system. The unit is EIC's DPV-140, cost \$60 and it mounts to the main TE cooler cold side output via small screws. The picture shows it mounted but does not show the output fitting.

The bottom has a brass fitting (not shown) that accepts 3/8" dia tubing that drains outside of the humidor and ensures that all of the condensate is removed from the humidor.

Water allowed to remain inside of the humidor will force the relative humidity level to rise. Since 70% RH is the desired level, rising beyond this point will damage the cigars in the humidor especially if the temperature is 70 F.

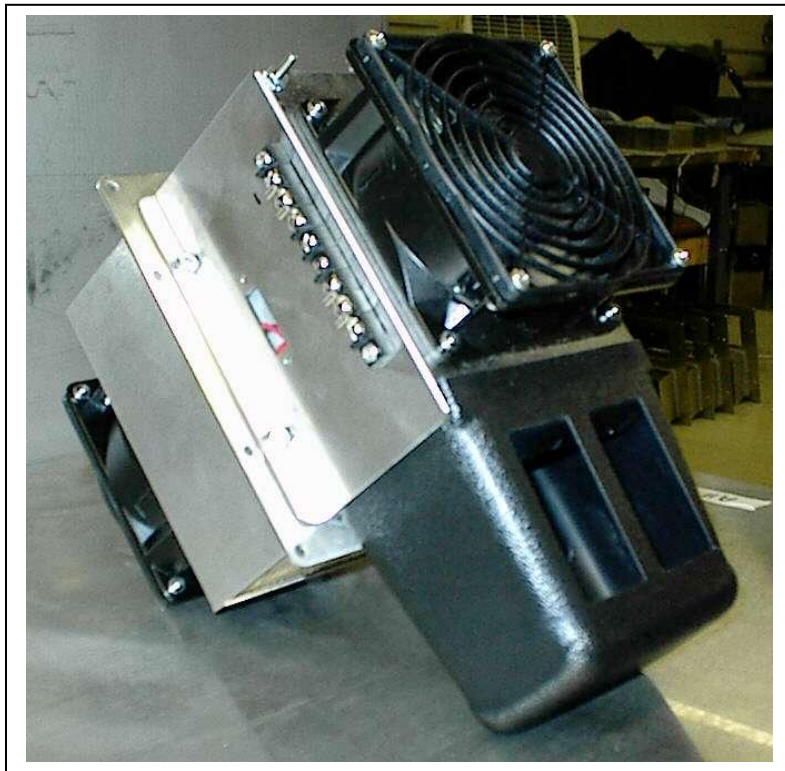

Power Dissipation Worksheet

File Units MELCOR Help

Select Configuration

- Volume Cooling (Passive Load in Insulating Container)
- Volume Cooling (Active Load in Insulating Container)
- Device Cooling (Insulated Device or Cold Plate)
- Device Cooling (Uninsulated Device or Cold Plate)

Container Dimensions

- Box Cylinder
- Length: 22 (in)
- Width (W): 23 (in)
- Height (H): 28 (in)

Cooling Requirements

- Ambient Temp (Ta): 85 (°F)
- Internal Temp (Ti): 70 (°F)
- Active Load (Volts x Amps):

Insulation Properties

- Thickness (t): 1.3 (in)
- Other Insulation
- Thermal Conductivity: 0.077 (W/m-K)

Material Properties

- Density: (kg/m³)
- Specific Heat: (J/kg-K)

Requirement for Heat Pumped from Cold Side

- Passive Heat Load (Watts): 39.98
- Surface Area (sq in): 3532.0
- Internal Volume (cu in): 10052.3
- Steady State Heat Load @ Tc (Watts): 39.98
- Qc Requirement (Watts): 39.98

Clear Requirements Print Return to TEC Selection

The chart above is repeated to show the needed thermal power, Qc of apx 40 watts of cooling.

Plotting this requirement onto the performance chart shows exactly the required cooling and how much spare cooling is available.

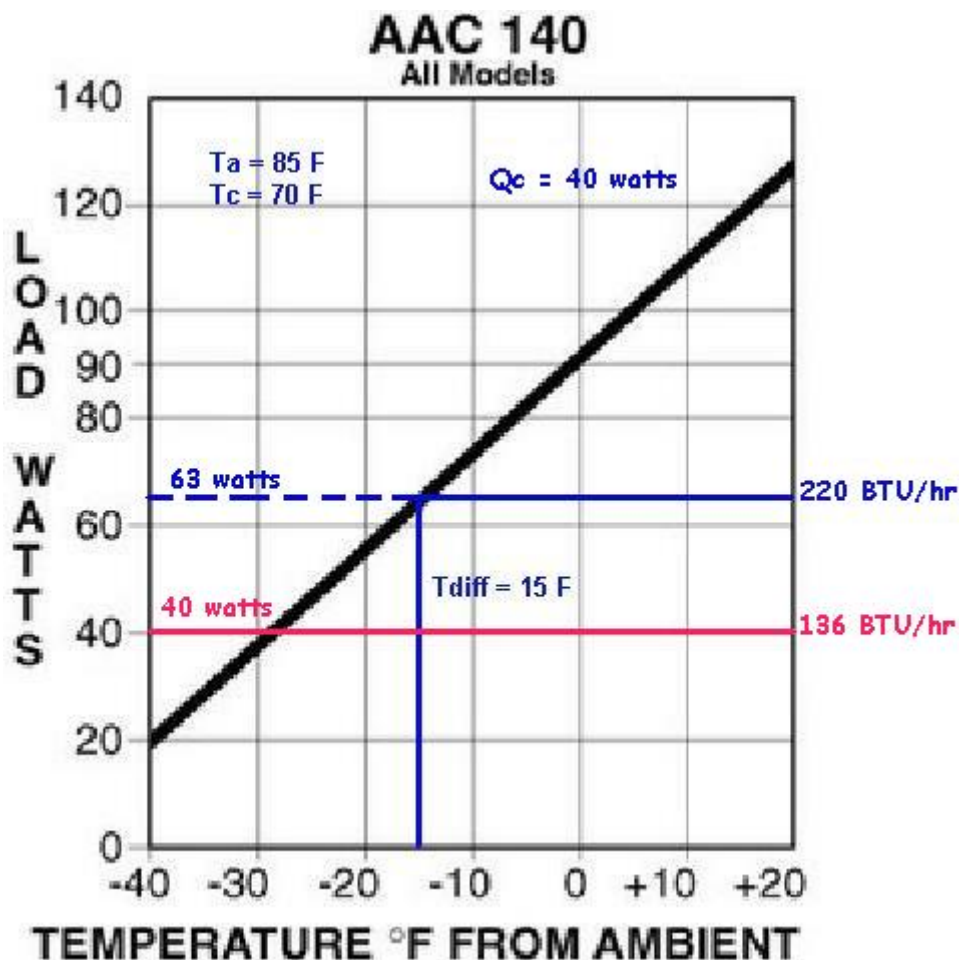

The performance curve shows that this TE air cooler has considerably higher power than the ACC-120 b/c the load line (Qc) shows the 40 watts (136 BTU/hr) which is contained within the **load-cooling envelope of 63 watts, about 215 BTU/hr.**

Even at an ambient temperature of **85 F**, the heat load from the cigar humidor loss is easily handled. There is about **"23 watts"** to spare, so this may be overkill but it's nice to have especially since it doesn't cost any more than the smaller AAC-120-4XT cooler however, it's not as 'clean' solution the smaller, self-contained unit.

Mounting Problems:

Some problems were uncovered when looking into mounting both of the TE coolers.

1) **No problems with the AAC-120-4XT unit.** It will mount with no difficulty. Requires a precision hole (5.188" x 7.375") to be cut into the back of the humidor. The unit is housed in a stainless steel case and is complete as shown in the picture on page 6. The humidor's 1.25" wall thickness will not interfere with mounting or controls of this unit.

2) **Problems w/ the AAC-140-T.** This TE cooler requires a precision hole (6.12" x 6.25") to be cut into the back of the humidor. The problem arises b/c the walls are 1.25" thick, so there must be at least 1.25" between the

flange and the condensate catcher (DPV-140). However, there's no 'dead' space between the flange and cold fin exhaust. Thus the airflow is blocked (by the humidor's thickness, 1.25") so the use of this TE cooler is out!

There's no way of mounting the condensate catcher and that feature is *mandatory* for a cigar humidor! The picture shows a close-up of the mounting flange and the lack of clearance due to the mounting of the DPV-140 condensate catcher.

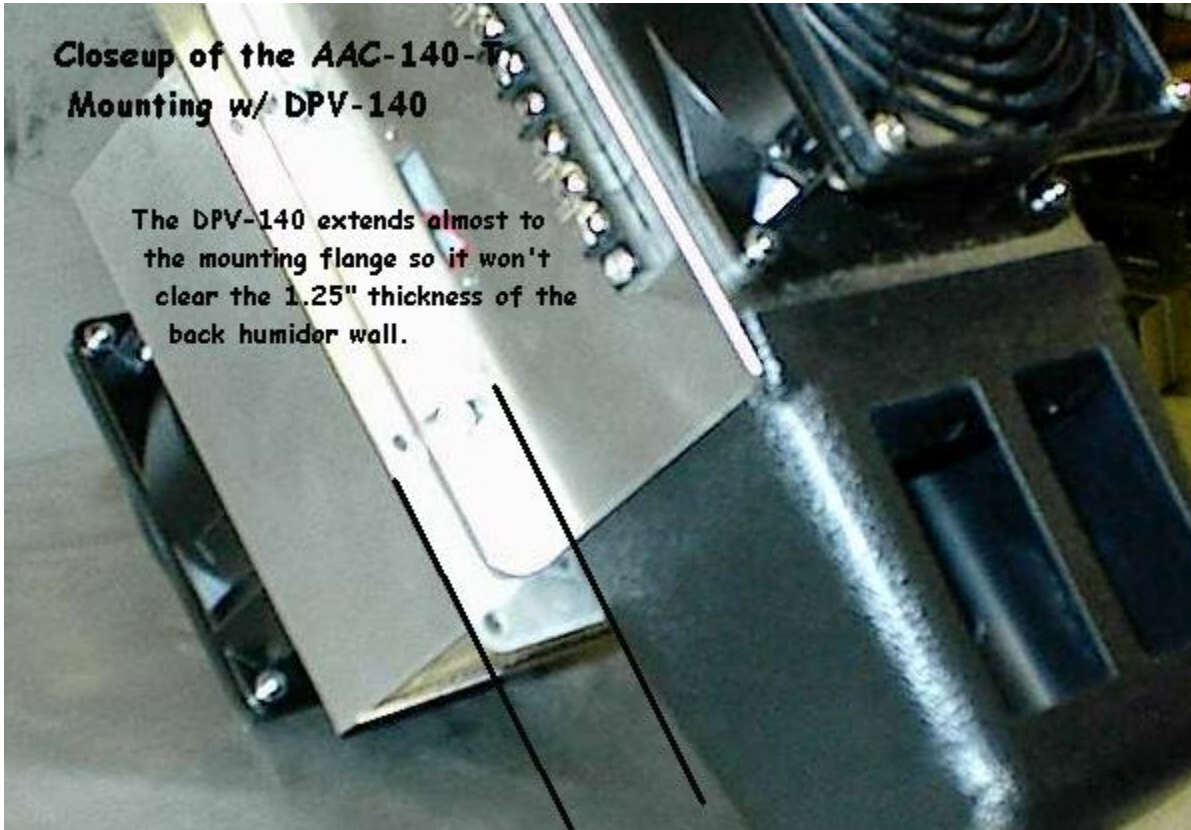

Summary:

Remember that I have increased the composite TC by 50 - 60% so the thermal load stated (40 watts) is on the high side. The conclusion is that I can use either TE cooler. The AAC-120-4XT has the advantage that it's completely self-contained. It doesn't require a external power supply, and remote temperature controller as the AAC-140-T does. Also the former has a built-in condensate system whereas the latter requires another add-on part.

However, when the mounting problems are considered, I am forced to use the AAC-120-4XT unit, not a bad consequence!

The next major step is the mounting of the TE cooler into the humidor. That section will be added along with pictures showing the details of the installation.

Received the "Real-Thing":

The AAC-120-4XT was received yesterday and tested on the "bench". The first thing I noticed was the direction of the airflow. It was 'backwards' from the direction shown in EIC's documentation. All of their promotion materials show the air as exiting the "top" or through the "fan" as shown below. The airflow pattern is 'clockwise' from the cold-side fan. As received, the airflow was 'counter clockwise'.

That was kind of a shock so after checking with EIC, I was told that they found that the unit worked better if the airflow was reversed due to "impingement airflow".

Basically, impingement is a form of convective heat transfer where air flow is perpendicular to the surface of the device. Unlike a conventional axial-flow fan, impingement generates very high, localized velocity jets through radiused holes or v-shaped slots.

So strictly speaking, impingement requires the use of specially formed slots and/or v-shaped holes so "air-jets" are generated. EIC's definition of impingement airflow is very loose indeed b/c it uses a 'conventional' heat sink. That is probably why my test showed no difference.

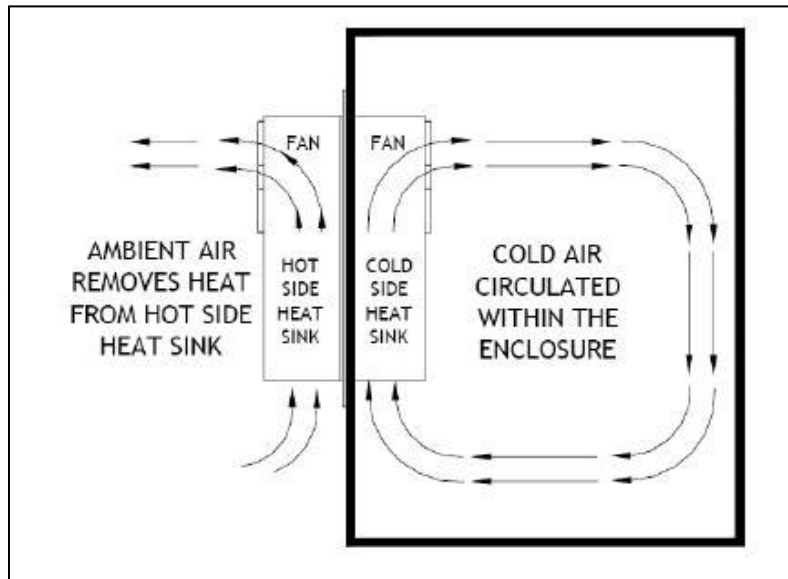

So being one of those "show-me" guys, I tested their "impingement flow". For those who don't want to read the details, my physics predicted that there should be no difference b/c there was no specially formed-air-processing structures!

The physics has to do with the size and capability of the TE cooler more than it does with the direction of the fan flow. IE, if the cool portion can produce so much cooling, forcing the fan flow one way or the other, doesn't affect the amount of cooling provided the fan has the same air volume in both directions. This is what I suspected and it proved true. The fans were symmetrical so the same volume of air flows across the heat sink (H-S) in either direction.

So if the cooling power of the TE device remains the same (it *does*) and the fan volume and flow remains the same (it *does*), the temperature of the exiting air should be the same (it *is*).

Certainly the profile is changed but the same exit air temperature was measured. The test was in my office: **temp of 23C**; AAC-120 mounted on the edge of a desk so the 'hot-side' was either exiting or drawing air over the floor (infinite baffle). The cold side outputted air along the desk's surface in both cases; of course, it exits differently depending on the fan's direction.

The coldest temp in the as-shipped case was **15C** and it was identical in the fan-reverse direction. The cold "spot" was, as you would think, at the top of the cold side exit with the cold-fan reversed. That's logical since the air is gets colder as it transverses the length of the cold side H-S. It also has a better "fan-out" effect that is desirable for a cigar humidor. It slightly angles up with "fan" pattern. All in all, the "normal" airflow is much more suitable for a cigar humidor.

Cut the "hole":

This is the toughest part of the cigar humidor modification! The "Through Mount" requires that a precision hole be cut that is **5.188" x 7.375"**. The TE documentation comes with a precision template that is to be cutout and pasted on the back. It is shown to the right.

The best way to do this job IMO is to use a router with a rabbit bit. The thickness of the back panel is apx 1.25" so a long bit is required. In order to ensure a good clean cut, a "fence" rail should be used to serve as a stop so the router has a solid reference line with which to cut.

We have decided to use a "high-power" jigsaw instead of a router. The h/p Bosch uses 7 amps and to makes up to 2800 SPM, saws per minute. It doesn't wander b/c of its superb balance.

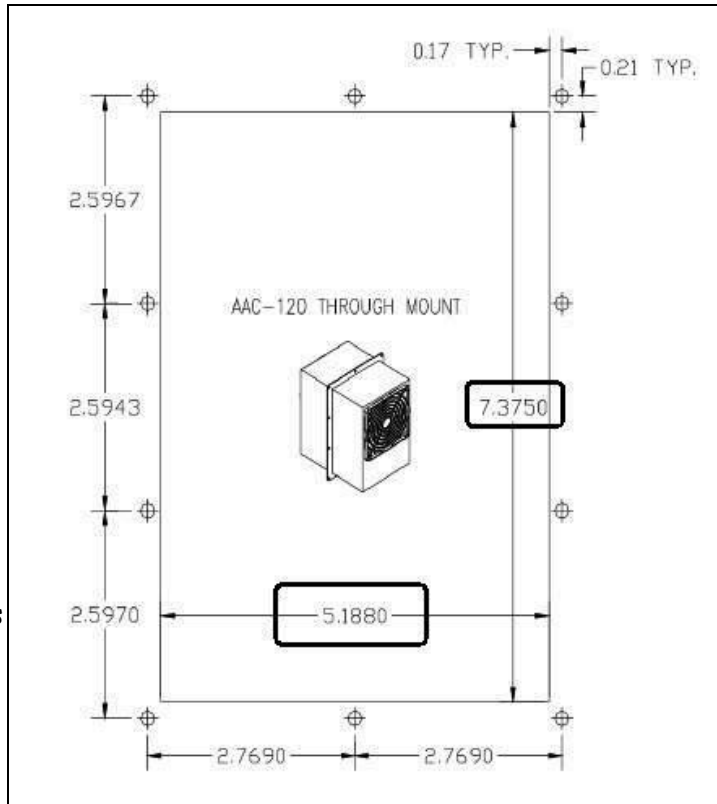

One of the main reasons that I chose this TE model was the built-in condensate drain system. The drain nipple is shown on the right. This mates with a plastic tubing that removes the condensate from the humidor via a small hole cut into the back wall.

This is an extremely important and if you choose to ignore the drainage you will be not very happy b/c your cigars may become very soggy!

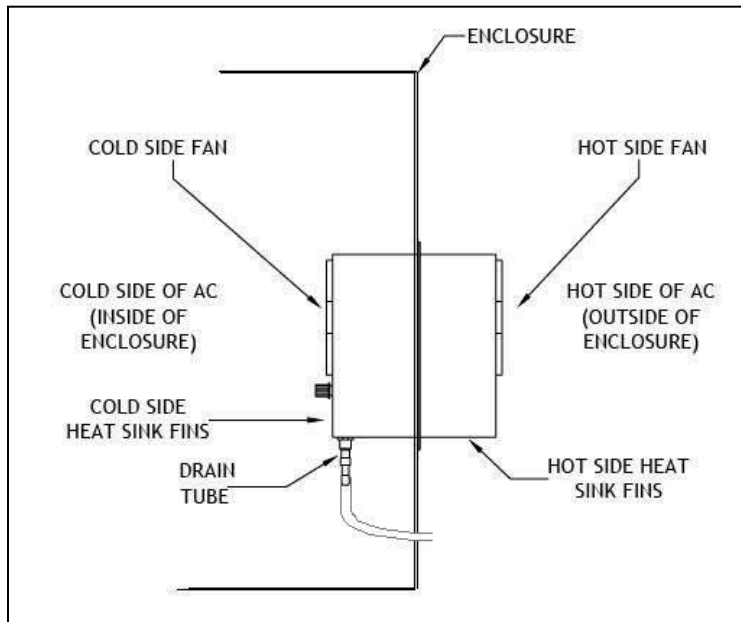

The picture shows the supplied template taped to the back of the humidor all ready to cut the hole for through-mounting of the TE cooler.

The masking tape marks the bottom of the internal shelf. Make sure you leave enough clearance for the TE cooler. In my case, the shelf comes within 1 - 3/4" from the back wall and the TE cooler's cold side depth is apx 3 - 1/2", so this is a very important dimension.

The condensate drain hole should be drilled at an angle of 15 - 20 degs so as to ensure that the plastic tubing will not kink.

The supplied screws are #8 - $\frac{1}{2}$ " metal screws and are not suitable for a humidor. Take a trip to your hardware store and get 10 - #8 - $\frac{3}{4}$ " wood screws. These are perfect for the holes pre-drilled in the TE cooler when you use the supplied nylon washers (back wall thickness is 1").

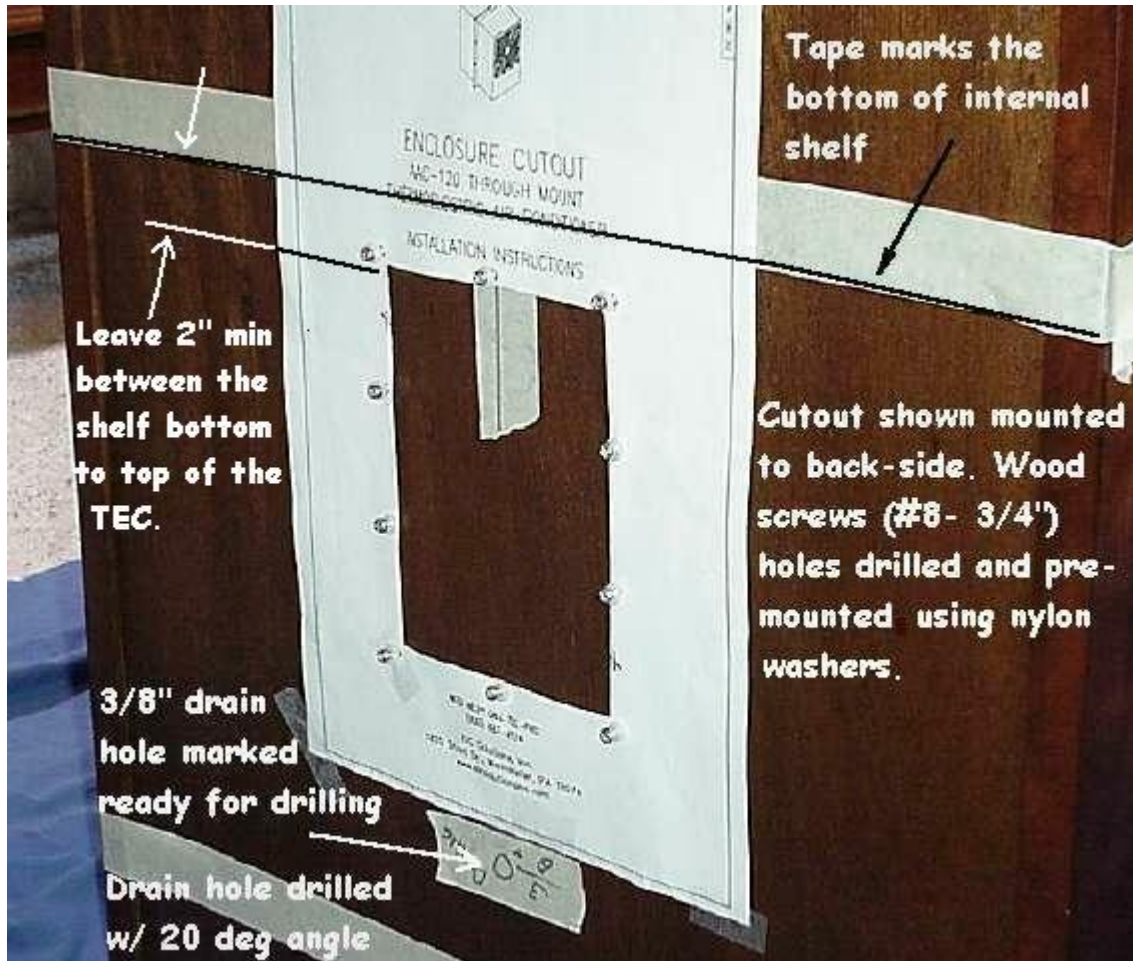

As was noted earlier, we decided to use a hi-power jigsaw. The Bosch model 1590EVSK requires 7amps and can make up to 2800 SPM. It has suburb balance that prevents it from "wandering".

Finish the Job:

After a trip to pick up a fine tooth saw for the jigsaw, the cut was completed w/o any difficulty. The TEC was mounted (after a little sanding) into the hole, screws tightened and the power was switched on and cooling was the name of the game!

The TEC cooled to about 68 degs within 5 mins and my cigars were installed in their new 'cooler' home. The hot side fan cycles every 15mins or so. Only complaint is that it's fairly noisy. I will address that later. The internal (cold) fan is not audible outside of the humidor so that was a pleasant surprise.

The picture shows the outside completed. A plastic container was used to hold the condensate; it's a bit large but I'll find a better solution in the near future.

The tubing shown to the right was cut at 30 degs or so which guarantees that it won't kink or bind. The plastic drain hose is visible in the picture below.

The picture below shows the TE cooler's cold side. The fan shield was removed b/c the fan's air direction was reversed and the air pattern resembles a "fan" in this position. This is ideal for disbursing colder air around the humidor.



The tubing shown above was cut at 30 degs or so which guarantees that it won't kink or bind. The plastic drain hose is visible, as it exists the humidor in the picture above to the right.

Humidifier:

I've used a Cigar Oasis II humidifier since the humidor was new. I works well and once you get the hygrometer trip-point set properly, it maintains the humidor at the desired temperature. Of course, more cigars will require more moisture so that determines the humidifier's RH load.

Plans are to see if the condensate generated by the TE cooler will be adequate to act as a humidifier as well as a air cooler. As of now, it won't since "zero" condensate has been collected. The RH here in So Cal has been typically holding around 40- 50%.

[The CO II humidifier was replaced with the newer CO XL Plus. See pg 22]

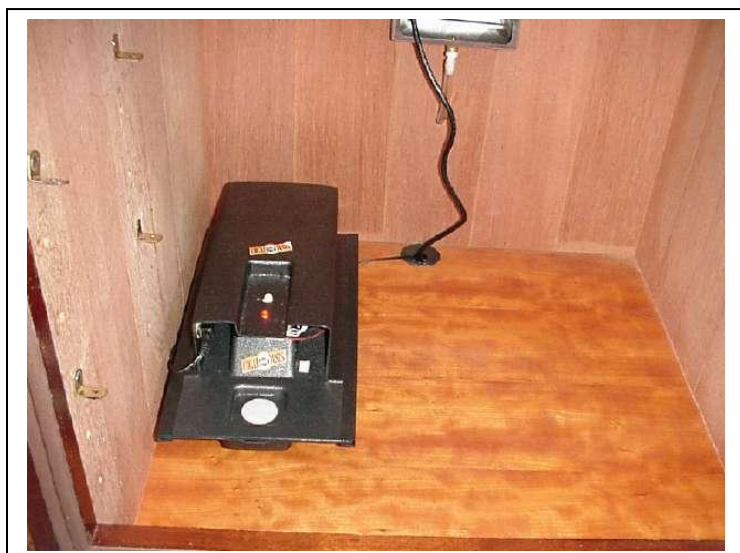

The initial settings of the TE cooler is shown as the humidor was set into operation. The RH was 69% and the temperature was at 67.2F as the picture shows.



Results - 8 days later:

The weather has been cool, around 67 - 70 F at the warmest except for today where it was 72F. Inside my house, the temperature topped at 73F. The RH has been very low, 40 - 60%.

After 8 days, the temperature picture shown above (at the startup) is very close to what we see today. The relative humidity has held at 69% since startup. What is outstanding is the humidor's temperature control.



The humidor's temperature has held within one degree since startup. In fact, it was less than 0.7 deg spread! That is much better than I expected. It runs for 3 to 4 minutes every 15 mins. The 'hot' fan is a bit noisy when it comes on so I'll need to make some changes at a later time after the novelty wears off!

Update, 5/18/08: Today, the outside temperature was 97F, inside was 80F. The humidor's temperature was 68.7F. *It had risen only 1 deg F!* During these conditions the TE cooler ran every 8 - 9mins for 3-4mins. The temperature controller exhibited less hysteresis than the +/-3 degs specified so it operated like EIC's digital controller speced to maintain +/-1 deg temperature variation.



The temperature regulation certainly implies that the humidor is well insulated and that the extra steps taken were worth the effort required.

When I open the door, it's a new experience to touch a "cool" cigar. Literally speaking, it's a new experience!

Hot-Side Fan Noise:

As noted earlier, the hot-side fan noise is fairly high and can easily be heard across the room. So the time has come to do something to reduce it.

The fans (both hot and cold) are made by YS Tech [<http://ystechusa.com/dc120series.html>]. After investigating, I found that their fans are usually noisier than other fans (Papst or Nexus) but have a very long life. Both features are important but for my application, I favor less noise even if some operational life is the trade-off.

The hot/cold fans that EIC uses are 120mm x 120mm x 25mm. Here's is the specs:

Model No.	Rated Voltage (VDC)	Starting Voltage (VDC)	Operating Voltage Range (VDC)	Speed (RPM)	Max. Airflow (CFM)	Max. Static Pressure (mm-H ₂ O)	Current (mA)	Power Consumption (W)	Life at 40°C (L10Hour)	P-Q Curve	Noise Level (dB(A))
YW12025024BH-6	24	12	12~26.4	2600	106.1	5.8	280	6.72	75000	2	44.0
Reduce the fan's speed to around 1800 will reduce the noise by 10dB											
YW12025024BL-6	24	12	12~26.4	1800	73.0	2.6	100	2.40	80000	4	34.0

Inspection of the chart shows that a "L" fan is 10dB quieter than a "H" version. H= Hi Speed; L= Lo Speed. If the present fan speed was reduced from 2600 to 1800, that should significantly lower the present noise, **44dB** to **34dB**, a difference of **10dB**. However, the CFM will be reduced by apx 25% to **73CFM**. It remains to be seen what effect it will have on the TE cooler's operation.

Practically, this is a simple modification to the existing circuit; add the appropriate resistor in series with the 24V lead (+ side) going to the hot-side fan to reduce the RPMs. The value calculates as shown in the sketch.

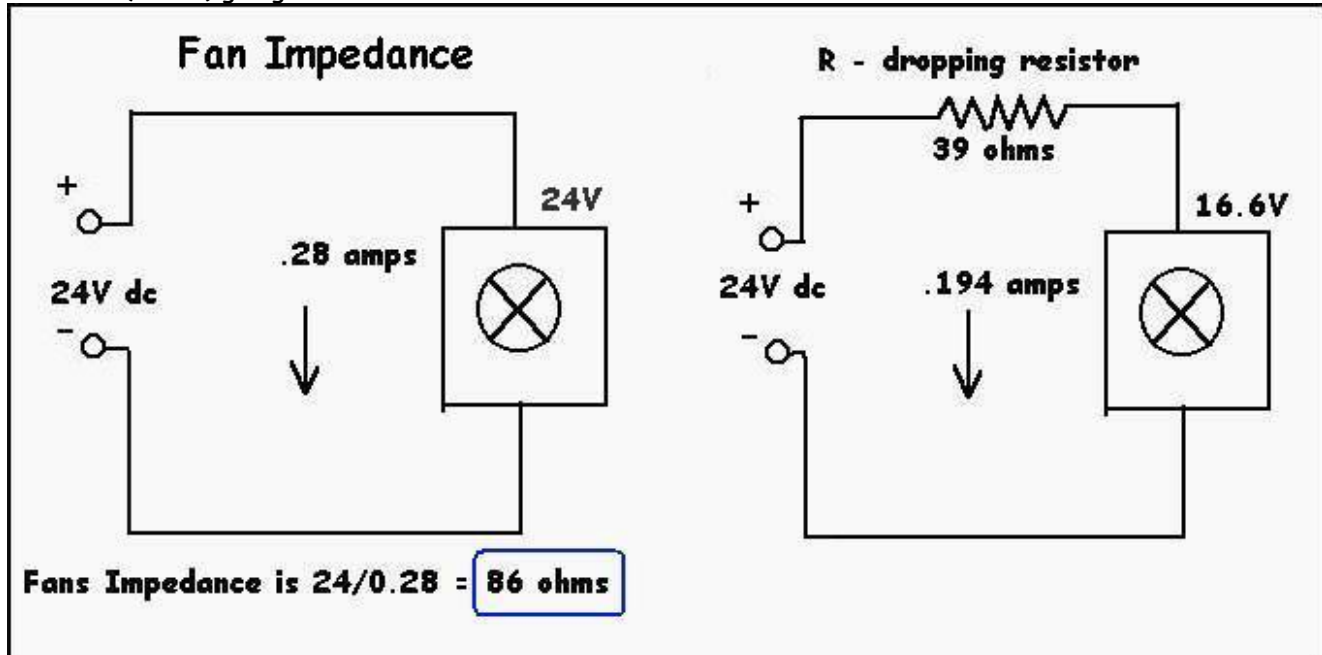

The fan's impedance is **86 ohms**, so to reduce its speed to 1800 RPM ($1800/2600 = 0.692$), you need to reduce the fan's voltage to apx **16.6 Vdc** ($24V \times 0.692 = 16.6$). At this voltage, the fan will draw **0.194 amps**, so the correct dropping resistor should be **39 ohms** (using standard values). The resistor 'drops' **7.5V** turning the supplied 24V into **16.6Vdc**. The resistor's wattage s/b a minimum of **2 watts**.

The picture shows how the resistor modification was implemented.

The measured voltage drop was **7.48 Volts** so the calculations were correct. The measured input voltage was **24.2 Volts**, therefore the hot side fan has **16.6Vdc** as its power, so it should rotate at **1800RPM**, producing **75CFM** of air movement.

The 39-ohm, 2watt resistor was mounted so that the exiting-air provides some additional cooling. The resistor's heat dissipation is **1.5Watts** so the exit-air helps cool it. The fan's shield was removed to make sure that the maximum amount of air is drawn into the hot-side heat sink and the fan was turned around to ensure that this happens. Airflow direction is shown above; this is EIC's preferred airflow direction. The 'hot-glue' serves to hold the resistor in the exiting airflow stream.

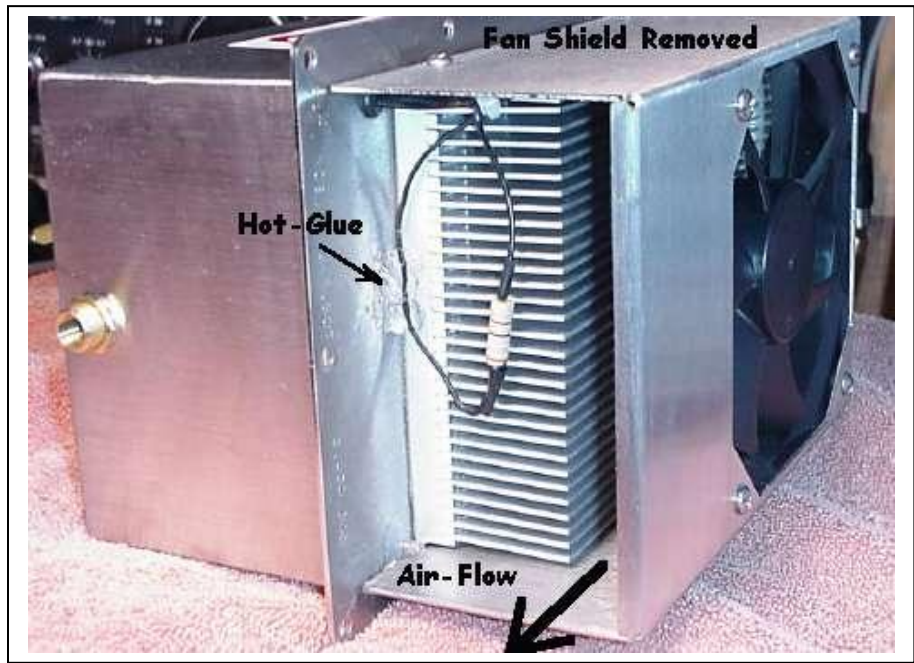

After it was installed into the humidor and powered up, I was extremely pleased b/c the fan was so quiet that it *couldn't be heard except when I was next to it!* It appears that somewhere between 1800 and 2600 RPMs, a whine ensues due to the fan's mechanical structure/blade geometry and that's what propagates around in a hard-walled room. At 1800RPM, there's no mechanical noise from the fan, just a 'swishing' noise due to air movement. Very pleased with the results!

The other good news is that the TE cooler's temperature regulation hasn't changed; still cycles about every 9 - 11 mins for 3 - 4 mins. So I can now pronounce this a successful modification. For those who don't want to modify the fan, purchase the "L" version (YW12025024BL-6) and it will drop directly into the EIC circuit w/o modification. In addition, the "life" of the fan has been increased as the spec comparison chart shows.

Settings:
This table summarizes a range of conditions that generally work for most people.

Temp (F)	Water Vapor Pressure	Relative Humidity (%)
66	16.37	80.33%
67	16.95	77.58%
68	17.55	74.93%
69	18.17	72.37% ← high variation
70	18.79	70.00% ← ideal!
71	19.45	67.61% ← low variation
72	20.11	65.39%
73	20.81	63.19%
74	21.51	61.13%
75	22.25	59.10%
76	23.00	57.17%

Some ask what settings should I use for storing my cigars?? That usually elicits as many different settings as there are days in the year b/c that answer depends on where and how the cigars are stored. It could be in a main room, an upstairs den (hot) or even a cellar (damp). So the "place" as well as "how" they are stored will dictate what settings are best for that humidor.

Although "ideal" temperature/humidity for cigars is supposedly 70° temperature and 70% humidity, your cigars are actually better off at a cooler temperature. However cold, below 60F, will alter the long term aging of your cigars.

IMO 68° and above is quite acceptable and will help prevent mold. Mixes of 69°/72% or 72°/65% are also fine. If you can maintain 70°/70% with no problems, you shouldn't go wrong. Just remember that as you lower the temperature, you should raise the humidity to maintain the proper moisture content. In general, keeping your humidor in a relatively cool place is a good idea.

My desired settings are 70F with 70% humidity; the RH range is from 67% to 72%. A sudden rise in temperature coupled with a relatively high RH could have serious consequences to a cigar. It's best to err a little on the low side for the humidity setting. A 'damp' cigar is not a pleasant smoke! (The section below describes the difficulties encountered.)

Temperature-Humidity Management:

The weather here in So California has been very hot for two (2) weeks, to the tune of **100F with up to 85% RH**. With the temperature/humidity gauges placed where they were it soon became obvious that they were not at the optimum location.

Why? The main gauge was located as shown on pg 19 (upper left-hand corner at the top). It only takes a few minutes to see that "hot-air" rises so that location shows the 'hottest' readings b/c it's at the highest place in the humidor. Also it's farthest away from the TEC. As a result, it doesn't read the actual cigar conditions; temperature readings were high and humidity readings were low.

Second, the main sliding-drawer (s-d) covers the top of the TEC such that the air output is blocked from entering the s-d. The sides are also blocked from any air movement. The **only** place left for air to enter is the space between the end of the drawer and back wall of the humidor, about 2". Some cooled air can get into the drawer via the $\frac{1}{2}$ " to $\frac{3}{4}$ " space between the floor slats. About 30 - 35% of the cooled air gets into the open cigar area in the s-d. This was obvious as I moved the placement of the gauges. The main gauge read 70 - 71F when the actual temperature on the shelves below the sliding drawer was **2 - 3 degs cooler**, about 67 to 68F. With that now known, changes in the placement of the humidifier and readout gauges are needed to get more correct readings. (Later, I found that these settings exceeded the dew point producing too much condensate.)

Also found that the original CO II (large black 'box' shown on pg 18 in the bottom picture) was just too large for the humidor. I had to use a timer to completely shut-off the CO II for 3 hours or more and run it for only 15 - 30mins. If it ran continuously, the RH would creep up finally getting too high for safe, long-term cigar storage. [At this point some suggested the use of "humidification beads"; see page 25]

New Humidifier:

I purchased a **Cigar Oasis XL Plus** humidifier that is supposedly rated for up to **10cu ft humidor**. My testing shows that it would have a hard time humidifying anything over **8 cu ft**, the size of my humidor. I would say that it could realistically handle from **2 to 6 cu ft humidor**. One of its positive features is that it's "sealed". It's not hermetically sealed but sealed enough to not 'leak' humidity into the humidor as does the original CO. The device has an open structure where water vapor can easily leak out due to the two (2) small fans that run

continuously affecting the RH of the humidior even though the microprocessor is not calling to run the main fan. The XL Plus completely stops its fan and so there's minimal leakage if any.

However, it is this structure that causes a problem. The large open area in the center of the water fill tray is located directly under the recirculation fan. The fan is shut-off when the RH is below the set point but the internal RH sensor is still active. So its problematic that it will indicate a higher amount of humidity than is truly present outside the CO's case. Typically it reads 2-3% higher. Once you know this, you can easily compensate for it. It could be compensated for in the design.

The new temperature/humidity management placement is shown in this picture. As you can see, the gauges were moved to the back and that moves them closer to the TEC and, in fact, places the main gauge right over the TEC. The aux gauge is just ahead of the TEC. BTW, the picture was taken today at home with the temperature of 100F and RH of 82%.



The new CO XL Plus was placed in the front compartment and elevated to raise the output to be above all of the cigars as suggested by CO. The round precision thermometer measures the temperature just **below** the bottom of the drawer. As I found, that temperature is about 3 degs F colder than above the drawer. That's a major problem and there was no easy solution to it as I found except placing the gauges as shown here. [This was solved by cutting holes; see pg 27]

The CO XL Plus is set to **67.0% RH**. The unit comes on within 0.1 degs of the set temperature, so with my settings, it comes on at 67.2 and shuts off at 67.4. Whether it's running or not, the RH is continuously displayed. It displays low water level indication alerting you to add distilled water.

The **average drawer temperature** is around 70F which allows you to run up to **70 - 72% RH** safely.

CO XL Plus Hygrometer Only Mode:

The CO XL Plus is hygrometer as well as a humidifier. To use it as a hygrometer **only**, do the following.

Remove the top section; block the three (3) holes in the water container using heavy 2" wide tape.

Assemble the top portion and power it up. Set the fan trip point to 79.9F.

This forces the internal fan to run continuously making it a highly accurate hygrometer that updates RH readings every 30 secs.

**An Experiment:**

One experiment was performed: the last floor slot (in the back row) was removed which opens the direct path to "see" the TEC as shown in the picture. As such, the TEC blows cooled air **both** up through the "holes" from by the slot's removal and allows cool air to get into the top of the humidor as well as blowing cooled air into the bottom section of the humidor.

With the new placement of the gauges, they now read closer to the colder temperatures and higher humidity levels present in the humidor. The problem arose when the RH levels approached **80%** with temperatures of **67 - 68F**. **At the time I couldn't figure why this happened.** That amount of RH is much too high and will ruin the cigars if left unchecked. The RH occurred in cycles and it was impossible to stabilize the humidor's temperature and humidity to safe levels. So the floor slat was re-installed.

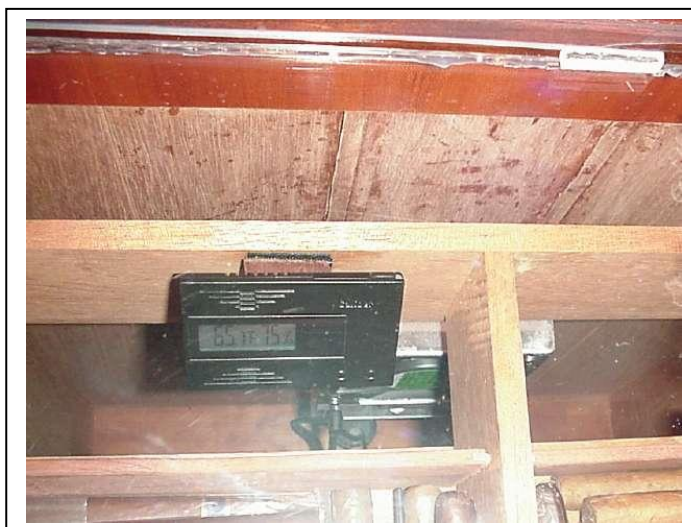
**Real Problem Found:**

The reason for the high RH was simple: **water in the form of condensate droplets were present on the heat sink's fins. Since the air movement through the TEC is "upwards" (was reversed, see page 15), water droplets can be seen suspended between the heat-sink fins.** They 'bobble' up and down as the air is drawn up and through the heat sink. It's easy to understand how the RH 'spikes' when the TE cooler cycles off and on. The constant airflow (cold side fan does **NOT** turn off) adds moisture to the airflow and raises the RH in the humidor mainly b/c of the fine trapped water droplets.

On page 7, I mentioned using the condensate as a controlled source for RH for the humidor. Now, since it's real, I **must** solve this problem or at least, control it.

When I removed the TEC assy, the water droplets were "saturated" onto the heat sink; millions of extremely small drops of water all over every inch of the heat sink. If metal heat sink fins can get 'soaked', these were! Also there were small drops on the fan blades. So to ensure that water is drained from the TEC, the fan's rotation was reversed so that the condensate is forced downward into the drain by airflow assisted by gravity. The TEC was indeed acting as a humidifier as well as an air cooler. Not a bad thing if I can control it!

After five (3) hours, the humidor's temperature was **69.5F** and RH was **73%**. Looking into the fan blades, no water droplets were visible . . . and the good news, there was a small puddle of water in the bottom of the TEC

drain. Not full enough to empty itself but enough that some had flowed out the exit tube into the external drain cup. I thought it was fixed but it wasn't!

EIC TE Cooler Drain:

There's a problem w/ the TEC drain. A brass 'plug' is employed that threaded both inside and outside. The inside thread fits a small plastic adapter that mates w/ the plastic drain hose.

The problem is in the height of the brass plug. **The top is about 1/8" in height and that height forces at least 1/8" of water to sit in the drain before it can flow out.** This results in an excessive amount of water that will add to the RH level as the air flows over it.

Two things are needed to fix the problem:

- 1) **File the top of the brass plug to be 1/32" thick max. Grind or sand it down; simple fix.**
- 2) **Form the lower housing cover to have a convex bend so that condensate is gravity forced to flow toward the center. This will dramatically improve the drain characteristics. This was also done.**

RH Spike:

[This info shows that the TE Cooler's temperature was set below the Dew Point; See pg 26 & pg 31]

A RH spike occurs when the TE cooler switches off. The RH quickly builds up 3 to 8% over the present value. This is an RH 'spike'. As the TE cools, the RH is slowly lowered to the value before the spike.

In my case, when the TEC cycles off, the **RH goes to 76 - 80%** and then returns to normal in 3 - 5 minutes. It's not as high as it was but making sure that the water drains quickly would help a lot. The more water that drains out, the less the RH rise. With the higher humidity lately, the TEC is acting as an air cooler and a humidifier. Nice feature provided I can control it.

To **minimize the RH spike**, the humidor's temperature was raised to **69 - 70F**. At this setting, much less condensate collects and thus minimizes/eliminates the RH spike. But still the RH would rise!

Humidification Beads:

[This use of beads frustrated my TE cooler incorporation. I thought that these 'magic' beads would completely solve the RH problem and also maintain a constant RH in the humidor. Unfortunately, this was **NOT** the case, the 'beads' were the **source of the high RH levels and the RH 'spike'**. **I've included it so that you can see what happened. See PG 29 for conclusive bead tests.**]

It looks like that the only **sure** way to eliminate RH problems is to use "humidification beads". At least that's what I thought. These have the magic property of regulating the humidity to 70% (also 60% or 65% depending on version) b/c they absorb moisture when the RH rises or release moisture when the RH falls. All automatically and, to boot, they last forever provided you use distilled water.

Beads are a moisture sensitive silica material that absorbs and desorbs moisture in order to offset changes in RH. The beads are generally available preset for a specific RH for cigars of 65% or 70%. Humidification beads have the reputation for precise control of humidity and are 'best' in terms of performance, cost effectiveness and simplicity. There is nothing to wear out and all that is needed to maintain them is either the addition of distilled water or the drying out of the beads if they become water logged.

Companies that sell beads and other accessories:

"Heartfelt Industries"; (<http://www.heartfeltindustries.com/default.asp>).

"Bargain Humidors"; (<http://www.bargainhumidors.com/bh/ProductInfo.aspx?productid=ACC-CONSERVAGEL>)

An 8 cu ft humidor requires about 1.75 lbs of beads for passive humidification. I was told: *when a TE cooler is employed, you may need to double the amount of beads to minimize the RH spike*. I started with 1lb with little success. So another 1lb was added of 65% beads and mixed with the 70% making a composite of 68%. These were added to a shallow stainless steel pan with dimensions of 19" x 12" x 1.5". The bead depth is about ½". The less depth the better since more beads are in contact w/ the humidified air. For my application, no distilled water was added. Placed the pan into the humidor and you should be all set.

With the TE cooler set to 67F (69F as measured in the drawer), I started to see a rise in RH after a few minutes. [This was the clue but I didn't see it until later; see pg 29] It rose to 75% and it was 'real'; all three "gauges", showed the increase. At first, I thought that the TE cooler was the cause of the condensate but after checking, it was completely dry. But there WAS an increase in 'water-vapor' that caused the RH rise! The RH was running consistently over 73%, sometimes getting to 77%.

Finally A Real Solution (8/8/08):

We have been still been experiencing some high humidity days (80 - 85%) in So Cal and the humidor's RH has risen to levels that had me concerned; around 75 - 77%. So it's time to solve this problem permanently!

First let's make sure we all understand what condensate means! It's nothing more than the definition of **Dew Point (D/P)**. D/P is that temperature where the water vapor contained in the air "comes" out in the form of water b/c the air is saturated and can no longer hold the water vapor.

RH and D/P are closely related and are based upon the amount of water vapor in the air and the total amount of water vapor that the air can hold at a given temperature. **The warmer the air, the more water vapor it can contain.** Conversely, the cooler the air, the less vapor it can contain. This is why moisture condenses on a cold glass. As the air near the object cools, it reaches the point where it can't contain all the water which it held at a warmer temperature and some moisture is drawn out of the air.

RH expresses how much moisture is in the air, as a percentage of the total moisture the air can contain at the current temperature. For example, if the air has all the water vapor that it can contain at a given temperature, the relative humidity is 100%. So for a given amount of water vapor in the air, the relative humidity will change inversely with temperature. As the temperature drops, the air becomes relatively more saturated, and the relative humidity goes up.

Air Temp °F	% Relative Humidity																	
	100	95	90	85	80	75	70	65	60	55	50	45	40	35	30	25	20	15
100	100	99	97	95	93	91	89	86	84	81	78	75	71	67	63	58	52	44
95	95	93	92	90	88	86	84	81	79	76	73	70	67	63	59	54	48	40
90	90	88	87	85	83	81	79	76	74	71	68	65	62	59	54	49	43	36
85	85	83	81	80	78	76	74	72	69	67	64	61	58	54	50	45	38	32
80	80	78	77	75	73	71	69	67	65	62	59	56	53	50	45	40	35	32
75	75	73	72	70	68	65	64	62	60	58	55	52	49	45	41	36	32	
70	70	68	67	65	63	61	59	57	55	53	50	47	44	40	37	32		
65	65	63	62	60	59	57	55	53	50	48	45	42	40	36	32			

The chart shows the D/P temperature plotted against Air Temp (F) and %RH.

Looking at the chart from a "humidor" standpoint, the conditions represented by the intersection of **80% RH and 75F Air Temp show a D/P of 68F would be close to the conditions present in So Cal.** At this temperature, water will condense out of the air and be present on the fins of TE cooler. The RH will rise inside of the humidor.

So the 'trick' is to **set the TE cooler temperature to be higher than the D/P temperature**, 68F in this example. Set it to, say 70F. This should give you a safe margin even if the temperature rises.

Setting the TE cooler to 70F means that the humidor will, most likely, be around 71 - 72F. Using the chart on pg 21, the desired RH would be **65 - 67%**.

Humidor Mods:

In order to minimize the temperature differential between "in-drawer" vs "under-drawer", the following modification was made to the drawer.

- 1) **Drill 1-1/4" holes in the bottom slats and 2-1/2" holes in the back and front side as shown in the picture below. Six (6) holes in each slat along with four (4) holes in the front and back side.**



The **four (4) holes in the front portion** of the drawer are not shown. With the holes cut, the drawer is much more 'transparent' to both temperature and humidity and holds the RH as shown on the hygrometers. Compare this with the 'stock' drawer shown on pg 23. **The temperature differential is now a little over 1 deg F.** A very simple but elegant fix! [Note the front left hygrometer reads 3% low.]

This also refreshes the "cedar" since the drilling exposes fresh cedar; you will notice a stronger cedar odor.

2) Construct an air deflector that redirects the TE cooler's output air stream flow onto the floor.

[Note that this was done to pass the cooled air over the beads see, pg 29; shelves have been removed for the picture]

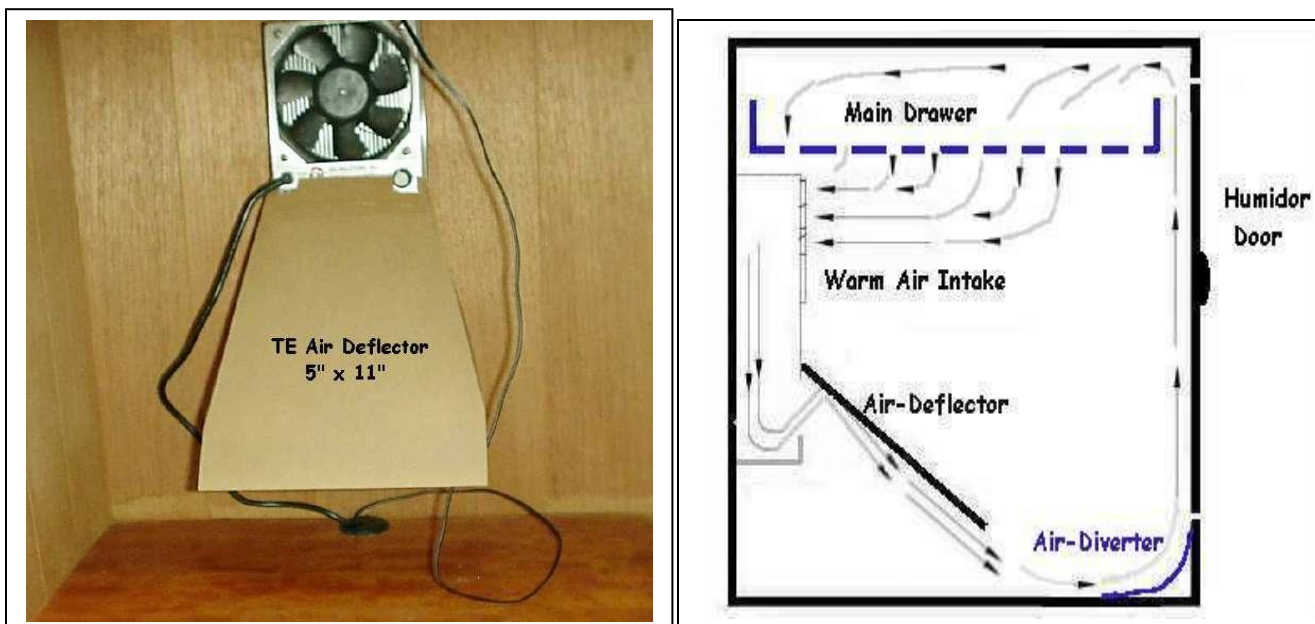

The air deflector does **at least two (2) things**: the obvious is that it directs the cooled output air away from the cigar drawer and onto the floor. The sketch shows how the air flows inside of the humidor. The **air-diverter increases the airflow efficiency** allowing more of the air to flow up the door panel and into the main cigar drawer. The output air stream from the TE cooler is at least 15 CFM and so no additional fans are needed.

The second, not so obvious, is that **the intake air stream and output air stream are not mixed as they were before**. The "lip" on the TE cooler causes a portion of the output air stream to **deflect upwards and mix with the input air** being drawn into the cold side intake as shown in the sketch. This adds more humidity to the already moist air stream. With the air-deflector in place, the **air streams are totally separate**. Separating the two air streams lowered the humidity level in the humidor.

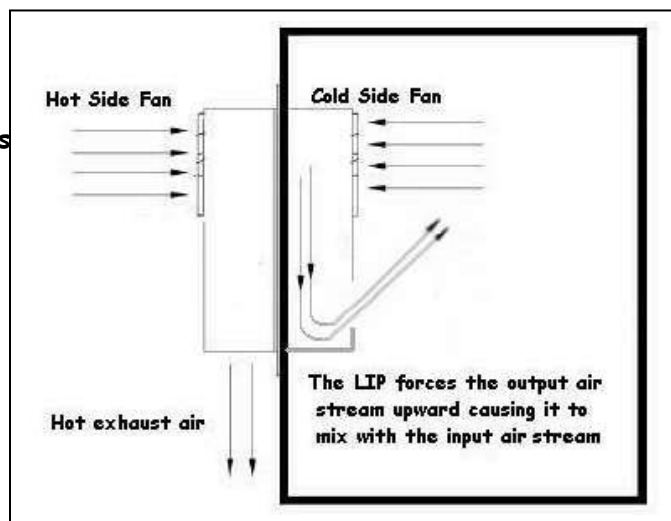

These two simple mods lowered the humidor's RH level. The room's ambient temperature was 80F w/ 80% RH when the pics were taken.

Finally some success!

The "break-through" was what I found when the beads were removed from the humidor. The section below details this finding. A must-read.

A Revelation:

I removed the pan holding the beads . . . and the RH dropped! What? Yes, it went down, big time! Removing the pan was accidental but it was the break that allowed the *real* reason for the high RH to finally be identified. The picture shows the former placement of the beads in my humidor.

It's simple to explain: **when dry (low RH) air is passed over beads, the beads respond by releasing humidity.** The beads "do-their-thing" by releasing as much moisture as they can to raise the humidity in the air stream! As more air passes over, the beads continue to release moisture to raise the RH. In my case the measured RH from the TE cooler's output air was 65% using the CO XL Plus as the 'measurement' RH gauge. [See pg 24]

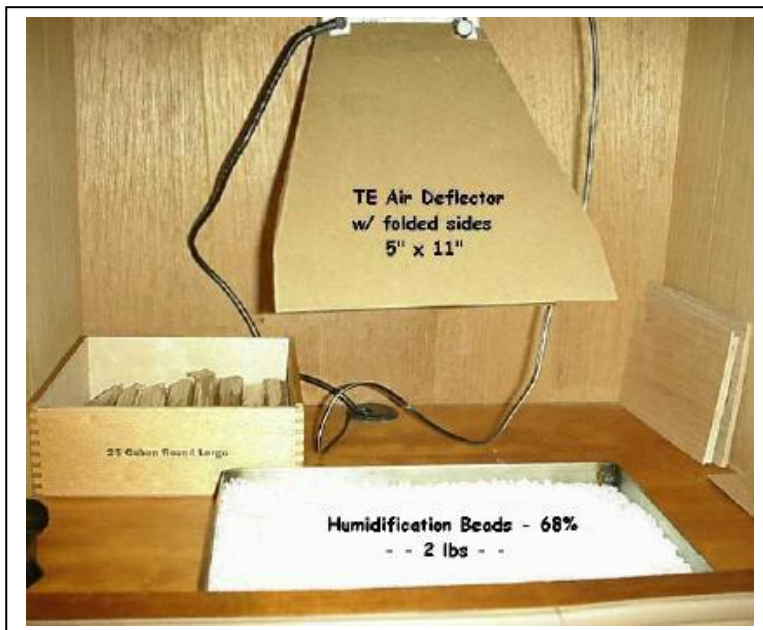

At first I couldn't believe what I saw but a number of experiments were tried and every time the beads did "their-thing". **A dry air stream will cause the beads to raise the RH within a few minutes. And the more beads you have, the more moisture that will be released!**

Conclusive Experiment: The 2lbs of 68% beads (picture above) currently being used were removed from the humidor and **baked in the oven @ 180F for 2.5 hours**. Periodically, the beads were 'stirred' so that as many beads as possible would be exposed to the oven's heat. The home's A/C was in operation to make sure the room's (where the humidor is kept) temperature and humidity were low; **temperature was 73F and RH was 61%**. Consulting the D/P chart on pg 26 shows the **D/P temperature was 55F**. So there's no worry about the TE cooler producing condensate due to ambient and/or internal conditions. The D/P temperature is well below the stated conditions. The TE cooler will produce cooled dry air.

While the beads were drying, the RH of re-circulating air was measured at 65% inside the humidor with the TE cooler cycling on and off as it does normally. Also, the humidor was 'dried' out (around 65% RH) while the beads were drying in the oven. After the beads cooled (inside the oven), they were transferred into the pan and quickly placed into the humidor.

Within 2 - 3 mins the RH went from 65% to 78% . . . BION! And this with mostly-dried beads. That should be enough proof for anybody.

If dry air is impinged on them, they will release moisture in an attempt to raise the humidity. And they continue to do so until the RH is equal to their set point RH plus some overshoot. They do this until the RH in the air finally stabilizes. Unfortunately, this value is much higher than it should be. Next the beads try to absorb the excess moisture to lower the RH to the beads RH point. This never quite happens b/c there isn't enough time to fully stabilize due to the TE cooler cycling ON and OFF. As it cycles, the moisture cycle continues but at a reduced level b/c of the saturation point.

These experiments have shown that beads **MAY** be wonderful in a passive humidification scheme but *since they both absorb and desorb moisture, they actually are a problem in this application b/c they operate automatically and can't be controlled.* I've not seen any data in the literature that shows how quickly the beads operate and in

this detail. **I believe we all thought that the so-called "RH spike" was caused by the air conditioner; ie, the humidity spike was due to the TE cooler producing excess condensate that the beads could not accommodate. The truth is that it's exactly the opposite!** So now you know the real reason!
[See "Condensate Generation" on pg 31 for possible ways to generate condensate.]

How about the use of 60% beads? Would they make a difference?? I don't have any otherwise I would have tested them. **If somebody wants to donate 2lbs of 60% beads for me to test, I will do so and report.**

Some corrections:

On pg 26; [An 8 cu ft humidor requires about 2 lbs of beads for passive humidification. *When a TE cooler is employed, you may need to double the amount of beads to minimize the RH spike.*] If you double the amount of beads, you will increase the amount of RH in the humidor during dry air blow over . . . BION!

Well, so much for the use of beads in **my** humidor. For humidor w/ TE cooling, beads are not needed or recommended. Note this is not like passive humidification of a humidor. In that case, the use of beads would be OK and recommended.

Summary & Conclusions:

This was a fun-project and my cigars thank me (or will I thank my cigars). The TE cooler design plus integration effort combined w/ beads showed a large amount of RH problems that can occur. As such, this was an excellent teaching experience. Here are the important points to remember if/when you decide to add a TE cooler:

- 1) The T/C simulation numbers developed here turned out to be accurate since the TEC chosen met the worse case conditions. So the methods/techniques developed in this report are OK to use and will give you accurate results.
- 2) All TE cooler devices **can** produce condensation if you **set the temperature below the dew point**. To compute the D/P for your conditions, use the table on pg 26. To minimize D/P problems, **set the TE cooler's temperature high enough above the D/P temperature**. This will minimize condensate problems. If you purposely generate large amounts of condensate, you will need to employ additional solutions other than those on pg 27 and 28.
- 3) The EIC condensate drain system on the TE cooler, as good as it is, is still wanting. **As delivered, the unit will not properly drain out the condensate**. The problem lies with the 'brass-plug' used and the lack of convex formed drain. Not major but it should be "fixed".
- 4) If you use an **EIC TE air cooler**, then I recommend the use of the **air-deflector and air-director**. This will guarantee that the air streams are kept separate and, as a side effect, it lets you direct the air stream where you want it. An air-deflector ensures that the TE cooler will minimize the condensate b/c of air-stream blending.
- 5) Humidification beads **can** solve humidity problems when used as passive humidification element but will **not** solve RH problems when used with TE air-coolers. As the TE cooler dries the air, the beads will add moisture. **The use of 65% or 70% beads will raise the RH level**. After removing the beads, the humidor now holds the temperature and humidity to very acceptable levels for cigar aging with NO RH spike as the TE cooler cycles.
- 6) An Electronic Humidifier (EH) **may** be optional if you live in a **consistently high humidity environment**, however, it will be required during low humidity periods such as "Santa Ana" (10% humidity) conditions

that occur in So Cal later this year (Nov - Dec). The CO XL Plus can be made to operate in a **hygrometer** mode using the steps outlined on **pg 24**. It's very accurate and updates RH readings every 30 secs.

- 7) TE cooler mounting (usually below the 'drawer') causes temperature gradients in the humidor. Typically a gradient of **2 to 3 degs F** can be seen by measuring the in-drawer vs the under-drawer temperature. This **may** cause other problems such as excessive condensate. So the "holes-in-the-slats/holes-in-the-walls" modification (**pg 27**) will **minimize the temperature and humidity difference between the top and bottom** in the humidor. For my drawer, the difference after the modification is a little over **1 deg F**. This allows a higher temperature set point for the TE cooler and, in turn, will lower the possibility of generating condensate. An alternate method is to **add an auxiliary fan** but that requires additional wiring and power. The EIC TE cooler I used produces about **15 CFM** airflow so adding an additional fan is really not needed. By using the **air-deflector and air-diverter**, the airflow in the humidor is efficiently directed into the main drawer (**pg 28**).

I have shown that the use of beads in a humidor with a TE cooler is not needed. The beads act in opposition to the air cooler resulting in the humidor being stuck in a never-ending, always-rising moisture cycle. You can get moisture from the TE cooler by careful setting of the temperature control.

TE Cooler Condensate Generation:

This section was added to make sure that there's no confusion about condensate (water) generation and how it comes about when your humidor is cooled using a TE air conditioner. There are two (2) ways this can happen:

- 1) **Without Beads:** Set the temperature control on the TE cooler to **below** the D/P. As the TE cooler cools the air, it will produce a large amount of condensate. There is nothing else that's needed in the humidor. If the air's temperature is below the conditions detailed in the Dew Point table on **pg 26**, the RH level in the humidor will always be high.
- 2) **With Beads:** Set the temperature control on the TE cooler **above** the Dew Point. The beads have previously acquired condensate (water) and they will put moisture back into the air in an attempt to balance the RH level to the bead's RH equilibrium point (details on **pg 29**) plus some overshoot. Again the RH will be high and always tend to rise. If you set the TE cooler temperature control **below** the D/P, you can use the cigars to wash a car!

All things considered, the project was a success and I now wonder why I took so long to do it! I credit the 'push' from the Club Stogie Forum [<http://www.clubstogie.com/vb/index.php>]

Thanks also to **Josh Liegel**, EIC Sales Engineer for data and drawings on their TE coolers.

It is cigar time . . . La Gloria Series R, #5, I earned it.

NOTE: The information in this document may be freely distributed provided this document is not altered or modified from the original.

Appendix

This section contains the information on the Thermal Conductivity of various products including the ones used in a typical cigar humididor.

The table shows the T/C of cedar and other wood materials:

TABLE 1—Mean value of thermal conductivity for selected wood species, MC < 15%.

Table Reference	Wood Species	Data, No.	Mean Temperature		Density		Moisture Content, %OD Weight	Conductivity	
			K	°F	kg/m ³	lb/ft ³		W/m · K	Btu · in./h · ft ² · °F
SOFTWOODS									
10	cedar	25	298	77	353.0	22.04	8.83	0.0932	0.646
11	spruce	33	300	80	383.8	23.96	8.27	0.0983	0.682
12	cypress	86	300	81	402.4	25.12	8.51	0.1128	0.782
13	redwood	40	300	81	399.7	24.95	6.98	0.1100	0.763
14	pine	110	299	79	432.6	27.01	7.57	0.1093	0.758
15	fir	27	300	80	435.5	27.20	8.47	0.1033	0.716
16	hemlock	39	297	76	458.6	28.63	6.52	0.1026	0.711
17	Douglas fir	27	300	80	496.6	31.00	6.50	0.1103	0.765
18	larch	23	301	82	523.3	32.67	10.26	0.1392	0.965
19	southern pine	76	298	77	559.8	34.95	7.18	0.1364	0.946
HARDWOODS									
20	elm	9	299	78	554.2	34.60	7.08	0.1350	0.936
21	birch	45	300	79	634.8	39.63	9.06	0.1465	1.016
22	maple	26	299	79	630.0	39.33	6.18	0.1500	1.040
23	ash	17	298	77	629.9	39.32	9.60	0.1456	1.010
24	oak	84	298	78	686.6	42.86	7.88	0.1638	1.136

This table of T/C shows the properties of various products from "air" to "wood". Of interest are the properties of "glass" and "Plexiglass".

Thermal Conductivity - (W/m K)

Material/Substance	Temperature (°C)	
	25	
Air	0.024	
Balsa	0.048	
Brass	1.09	
Brick dense	1.31	
Brick work	0.69	
Cement, Portland	0.29	
Cement, mortar	1.73	
Concrete, light	0.42	
Concrete, stone	1.7	
Corkboard	0.043	
Cork, regranulated	0.044	

Cork, ground	0.043
Earth, dry	1.5
Felt insulation	0.04
Fiberglass	0.04
Fiber insulating board	0.048
Fiber hardboard	0.2
Foam Glass	0.042
Plexiglass	0.19
Class, window	0.96
Glass, wool Insulation	0.04
Hardboard high density	0.15
Hardwoods (oak, maple, etc)	0.16
Insulation materials	0.035 - 0.16
Kapok insulation	0.034
Mineral wool blanket	0.04
Oxygen	0.024
Paper	0.05
Plastics, foamed	0.03
Plywood	0.13
Polyethylene HD	0.42 – 0.51
Polypropylene	0.1 - 0.22
Polystyrene expanded	0.03
PVC	0.19
Rock Wool insulation	0.045
Softwoods (fir, pine, etc)	0.12
Styrofoam	0.033
Urethane foam	0.021
Vermiculite	0.058
Wood across the grain, white pine	0.12
Wood across the grain, balsa	0.055
Wood across the grain, yellow pine	0.147
Wood, oak	0.17
Wood, felt	0.07